

2500 Series DP Flow

DIFFERENTIAL PRESSURE GAUGE
with FLOW SCALE

SHT. 1 of 2 Rev.-
SCALE 1/2"=1

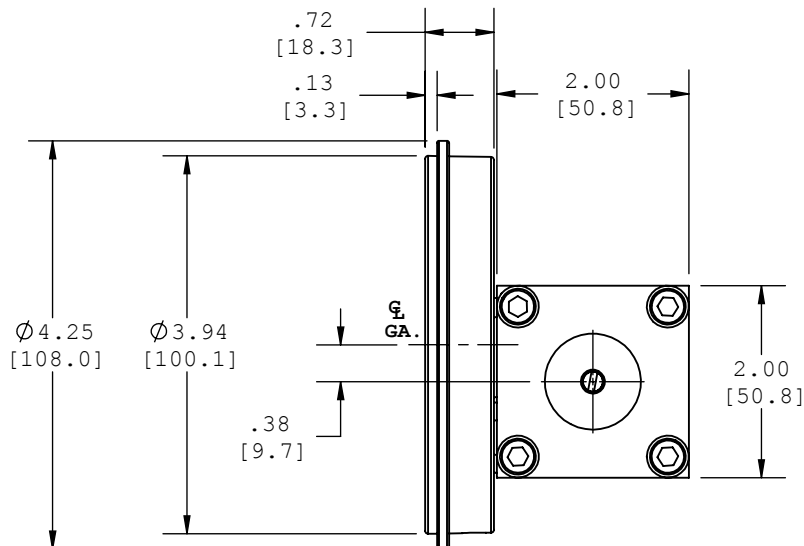
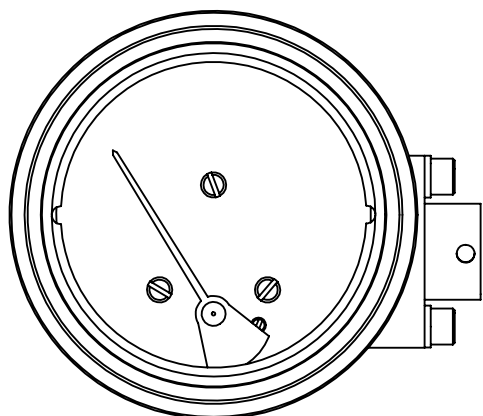

2510 SERIES - 1/2" NPT

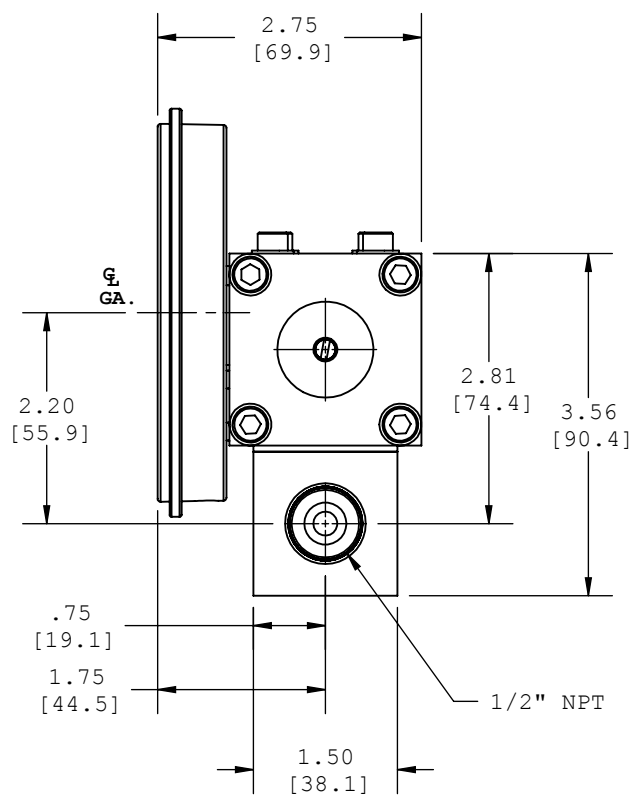
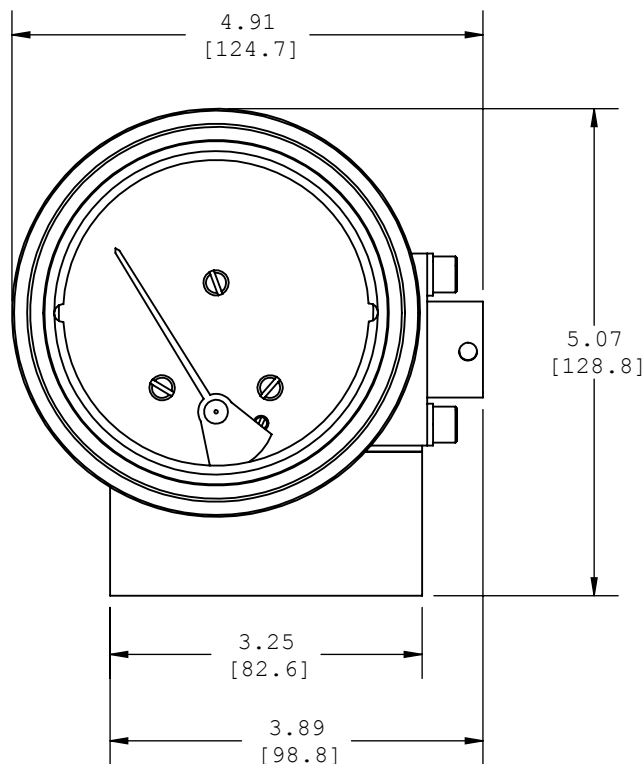

NOTE: DIMENSIONS IN BRACKETS ARE IN MILLIMETERS

